



WORKHORSE



EVS COLLECTION CARTS

**Tecni
Quip®**
Carts

**WASTE, BIOHAZARDOUS, BOX WASTE,
HAMPERS, JANITORIAL,
CUSTOM CAPABILITIES AND RECYCLING**



TQ-400 & 488 SERIES

Since 1961

For over 35 years helping America's health facilities collect soiled material in a Safe and Approved Manner.

TQ Series Complies With Joint Commission & Government Regulations

- Waste
- Biohazardous
- Soiled Linens
- Recycling
- Dietary
- Infectious Waste
- Easy to clean
- Seamless - no cracks or rivets

MODEL TQ-400 "A Rugged Reputation"

- Ultra Durable Cart - Engineered to Combine Aluminum Perimeter Frames with Strong Fiberglass Structure
- Accommodates All Sizes of Bags or Objects
- 5 Sizes** to Choose from *36 cubic foot to 90 cubic foot*



Easy to load via (2) top doors, split & hinged (Optional doors available - See reverse side)

TQ-400-11
36"x72"x70", 90 cu. ft., (Largest in the industry)



- Yacht-like Smooth Exterior Finish
- Aluminum Channel & Perimeter Wrap-a-Round Bumpers
- NEW** Stainless Steel Push Handles
- Easy to Load Split Door Opens Fully
- NEW** Durable Stainless Steel Hinges
- 8"x2" Ball Bearing "All Terrain" TPR Quiet Wheels & 8" Casters
- 30"x60"x60" **TQ-400-3**

Color Choices

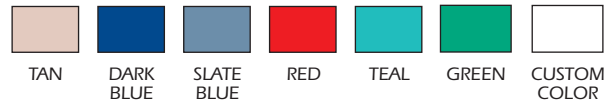

Custom Colors Available
Stenciling or Logo Available

MODEL TQ-488-2 "Working for You"

- Easy Top Door Loading Model.
- Size: 30"x60"x50" or *

Door opens fully for unloading and is suspended by easy to use "catch-me" chain. (Top door feature is *also available on any TQ-400 size & known as TQ-400-T



NEW Stainless Steel Push Handles

NEW Durable Stainless Steel Hinges
TQ-488-2 or **TQ-400-T** Style

Lower Door For Unloading + Easy Cleaning

TQ-400/488 Standard Sizes O.D. & Cubic ft/yds

Model No.	Size	Capacity Cubic Feet/Yards
TQ-400-1	27" w x 48" l x 60" H	36
TQ-400-3	30" w x 60" l x 60" H	50
TQ-400-8	30" w x 72" l x 70" H	75
TQ-400-9	36" w x 60" l x 60" H	60
TQ-400-11	36" w x 72" l x 70" H	90
TQ-488-2	30" w x 60" l x 50" H	38
TQ-400-T	Top door available on any TQ-400 Example: TQ-400-3-T	

Additional sizes available. Please call factory.



Quiet Carts

Premium Ball Bearing Wheels TPR Tread (All Surface Tread) makes TQ Carts So Quiet They Won't Disturb Your Patients



Tecni-Quip® Carts

960 Crossroads Blvd. • Seguin, Texas 78155 • Local & Int'l Ph: 830-401-4400
Fax: 830-401-0600 www.tqind.com • Email: sales@tqind.com • Toll Free **800-826-1245**





TQ-227 AND 236 SERIES



Since 1961

THE PERFECT COST EFFECTIVE COLLECTION CART

- Waste ▪ Biohazardous ▪ Soiled Linens ▪ Recycling ▪ Dietary
- Infectious Waste ▪ Easy to clean ▪ Seamless - no cracks or rivets



TQ Series Complies With Joint Commission & Government Regulations

TQ-227 & 236

Standard Sizes O.D. & Cubic ft/yds

Model #	Size	Cap. Cu. Yd.	Cap. Cu. Ft.
TQ-227	31" w x 42" l x 60" OH	1 cu. yd.	27
TQ-236	21" w x 61" l x 60" OH	1.5 cu. yd	36

Custom Sizes Available

Color Choices

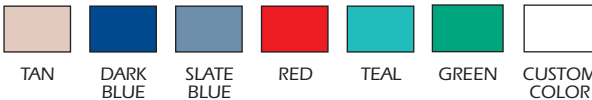

Custom Colors Available
Stenciling or Logo Available

Hinged top door safely rests on top of cart (no hardware necessary)

48" front slope allows ergonomic loading and bird's eye view of cart's contents

Quiet Wheels

Premium Ball Bearing Wheels
TPR Tread (All Surface Tread)



Doors are secured to cart body, prevents lifting and possible damage or loss to doors

Hinged lower door rests on top slope, safely

Unloading is safe and ergonomic through lower hinged door



Model TQ-227
"The Mail Box" Compact Size



Space Saving – Compare
¾ yard tilt truck cart 13.5 sq. ft.
1 yard tilt truck 16.8 sq. ft.
TQ- 227 = ONLY 9.0 sq. ft.

Model TQ-236
Cost Effective / Large Capacity



Space Saving – Compare
1.5 yard tilt truck 24.00 sq. ft.
TQ- 236 = ONLY 13.1 sq. ft.

Both Models Feature:

- Rugged fiberglass body - **Fire Retardant**
- Choice of colors and stenciling
- Bumpers - non-marking
- Large spillage bottom bin 3" with drain holes and plugs
- **Easy to clean** (no tipping cart or climbing in to clean)
- Smooth, Hard, Non-Porous Interior - easy to clean
- **TQ-Guard** a microbial agent - prevents mold, bacteria and mildew - Upgrade

Consult one of our in-house experts today! 800-826-1245



960 Crossroads Blvd. • Seguin, Texas 78155 • Local & Int'l Ph: 830-401-4400
Fax: 830-401-0600 www.tqind.com • Email: sales@tqind.com • Toll Free 800-826-1245



PROUDLY MADE IN THE U.S.A.

Quiet Carts

Premium Ball Bearing Wheels TPR Tread (All Surface Tread) makes TQ Carts So Quiet They Won't Disturb Your Patients

FIBERGLASS BULK CARTS FOR DELIVERY, TRANSPORT OR COLLECTION

Since 1961

TQ - 1000 SERIES

CLEAN * SOILED * PROCESSING

4 Sizes Available

MODEL	CAPACITY	CART WEIGHT	SIZE
TQ-1012	12 Bushel	60 LBS.	27"Wx37"Lx27"1/2H (34" O.H.)
TQ-1014	14 Bushel	65 LBS.	27"Wx42"Lx27"1/2H (34" O.H.)
TQ-1018	18 Bushel	80 LBS.	27"Wx54"Lx27"1/2H (34" O.H.)
TQ-1030	30 Bushel	135 LBS.	36"Wx60"Lx27"1/2"H (34" O.H.)

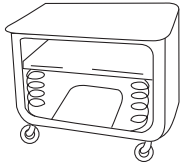

Spring loading bottoms available on all models



TQ-1014
With Optional Vinyl Cover
Solid Lid Also Available

STANDARD FEATURES:

- Casters 5", choose from caster options (see back page)
- Wheels 5" - all surface
- Drain holes with plugs
- Choice of colors

OPTIONS:

- 6" wheels and casters
- Parking Brake
- Ergonomic spring loading bottoms
- TQ Guard, antimicrobial agent
- Vinyl or Fiberglass covers
- Stenciling
- Perimeter Bumpers

TQ - 1200 SERIES

CLEAN * SOILED * TRANSPORT

3 Sizes Available

MODEL	CAPACITY	CART WEIGHT	SIZE
TQ-1224	24 Bushel	130 LBS.	28"Wx41"Lx57"H (65" O.H.)
TQ-1226	26 Bushel	130 LBS.	28"Wx48"Lx45"H (53" O.H.)
TQ-1228	32 Bushel	140 LBS.	24"Wx48"Lx58"H (66" O.H.)
TQ-1250	40 Bushel	175 LBS.	29"Wx59"Lx58"H (66" O.H.)

STANDARD FEATURES:

- Casters 6", choose from caster options (See back page)
- Wheels 6" x 2" - all surface
- Drain Holes with plugs
- Choice of colors
- Handles

OPTIONS:

- 8" wheels and casters
- Parking Brake
- TQ Guard, anti microbial agent
- Vinyl or poly drape covers
- Stenciling
- Perimeter Bumpers



TQ-1226, 53" O.H.



TQ-1250



Drape Covers available for all TQ-1200 & 1300 series models

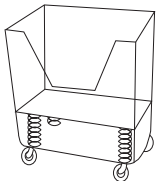

Ergonomic Spring Platform Bottom for TQ-1300



TQ-1300 Ergonomic Plus

TQ - 1300 SERIES

CLEAN * SOILED
TRANSPORT * SPRING LOADING BOTTOMS

3 Sizes Available

MODEL	CAPACITY	CART WEIGHT	SIZE
TQ-1332†	26 Bushel	130 LBS.	28"Wx55"Lx53"OH (32 cubic ft.)
TQ-1335	40 Bushel	140 LBS.	28"Wx55"Lx60"OH (49 cubic ft.)
TQ-1350	45 Bushel	180 LBS.	31"Wx61"Lx68"OH (56 cubic ft.)

STANDARD FEATURES:

- Caster 8", choose from caster options (see back page)
- Wheels 8" x 2" - all terrain ball bearing - non marking
- Full wrap around bumper, lower
- Drain holes with plugs
- Handles
- Choice of colors

OPTIONS:

- Parking Brake
- Ergonomic spring loading bottoms*
- TQ Guard, antimicrobial agent
- Vinyl or Poly drape covers
- Stenciling

*This model standard with 6" wheels (small)

Color Choices

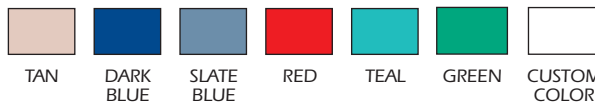

Custom Colors Available
Stenciling or Logo Available



960 Crossroads Blvd. • Seguin, Texas 78155 • Local & Int'l Ph: 830-401-4400
Fax: 830-401-0600 www.tqind.com • Email: sales@tqind.com • Toll Free 800-826-1245



TQ Carts Features and Options

TQ-400 & 488 Standard Features



Stainless Steel Push Handles

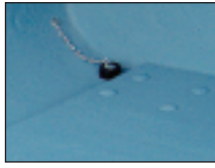

Drain Holes & Plugs



Easy "catch-me" chain

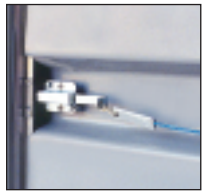

Secure Latches

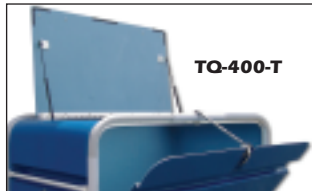

Add Top Door On Any Size of TQ-400 additional cost: Add -T to the end of Model Number; Example: TQ-400-9-T

TQ-227 & 236 Standard Features



Durable - Soft to touch handle located on Pushing Side of cart



Easy to clean lower spillage bin with 2 drain holes & plugs



Full length Stainless Steel Hinges Secure doors on to cart's body



Secure Slam Type Latches (2) attached with Cable, allows one motion to open door

Standard Features

Quiet Carts

Premium Ball Bearing Wheels
TPR Tread (All Surface Tread) makes TQ Carts So Quiet They Won't Disturb Your Patients



FIRE RETARDANT

Options



Air Spring



Parking brake



Interior Dividers * Available



Anti-microbial agent added to resin prevents growth of mold, bacteria and mildew*.

Caster Combinations All Models

FOUR SWIVEL

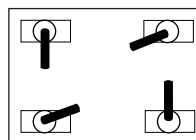

TWO RIGID, TWO SWIVEL
OPT. I

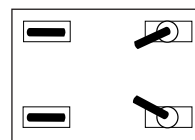

DIRECTIONAL SWIVEL LOCK
OPT. III*
FOR 360° MANEUVERABILITY

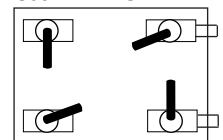



ALUMINUM BULK CARTS DELIVERY, TRANSPORT OR CUSTOM APPLICATIONS



Since 1961

AL - 1000 SERIES

CLEAN * SOILED * PROCESSING * CUSTOM

Sizes Available & Custom

MODEL	CAPACITY	WEIGHT	CART	SIZE
AL-1012	12 Bushel	70 LBS.		27" w x 37" l x 27 1/2" h (34" O.H.)
AL-1014	14 Bushel	75 LBS.		27" w x 42" l x 27 1/2" h (34" O.H.)
AL-1018	18 Bushel	85 LBS.		27" w x 54" l x 27 1/2" h (34" O.H.)
AL-1030	30 Bushel	90 LBS.		36" w x 60" l x 27 1/2" h (34" O.H.)

STANDARD FEATURES:

- Casters 5", choose from caster options (see back page)
- Wheels 5" - all surface
- Drain holes with plugs
- Perimeter Bumpers

OPTIONS:

- 6" wheels and casters
- Parking Brake
- Ergonomic spring loading false bottoms
- Vinyl covers
- Stenciling
- Choice of colors
- Push handles

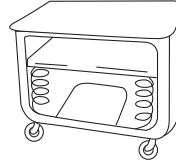

Spring loading bottoms available on all models



AL - 1014

Shown here in sparkling silver anodized aluminum

SPD - 1000 SERIES

SPD-1000-A

All Aluminum frame and panels

SPD-1000-B

Aluminum frame & colorful vinyl liner



Both models available in a variety of sizes and custom sizes

The Sports Models carts, shown above, fit in size 21" w X 43" l X 30" oh They fit into luggage bays of Motor-Coaches to hold sport team supplies and uniforms! Logos Priced Separately.

AL - 1300 SERIES CLEAN * SOILED * TRANSPORT

Sizes Available & Custom

MODEL	CAPACITY Cubic Feet	SIZE
AL-1224	24 Bushel / 33 cubic foot	28"Wx41"Lx57"H (65 O.H.)
AL-1226	26 Bushel / 36 cubic foot	28"Wx48"Lx45"H (53 O.H.)
AL-1250	40 Bushel / 36 cubic foot	29"Wx59"Lx58"H (66 O.H.)
AL-1332	26 Bushel / 33 cubic foot	28"Wx55"Lx53"H (61 O.H.)
AL-1335	40 Bushel / 36 cubic foot	28"Wx55"Lx60"H (68 O.H.)
AL-1350	45 Bushel / 60 cubic foot	31"Wx61"Lx68"H (76 O.H.)
AL-1300-S	Your Custom Size	

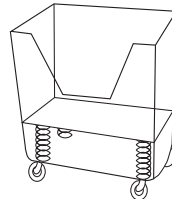

Ergonomic Spring Platform Bottom
AL-1300



AL-1300 Ergonomic

Variety of Size or Custom
Cut-out standard - or Custom height

SPD - 1000 SERIES CLEAN * SOILED * PROCESSING * CUSTOM

4 Sizes Available & Custom

MODEL	CAPACITY	WEIGHT	CART	SIZE
SPD-1012	12 Bushel		CALL FOR WEIGHTS	27" w x 37" l x 27 1/2" h (34" O.H.)
SPD-1014	14 Bushel			27" w x 42" l x 27 1/2" h (34" O.H.)
SPD-1018	18 Bushel			27" w x 54" l x 27 1/2" h (34" O.H.)
SPD-1030	30 Bushel			36" w x 60" l x 27 1/2" h (34" O.H.)
O.H.)				
SPD-SPORT	30 Bushel			21" w x 43" l x 27" h (30" O.H.)



FIRE
RETARDANT

See page 6 for Options + Create-A-Cart



960 Crossroads Blvd. • Seguin, Texas 78155 • Local & Int'l Ph: 830-401-4400
Fax: 830-401-0600 www.tqind.com • Email: sales@tqind.com • Toll Free 800-826-1245





Options Available For All Cart Models

Caster Combinations all models

<p>FOUR SWIVEL</p>	<p>DIAMOND SWIVEL</p>	<p>TWO RIGID, TWO SWIVEL</p>	<p>DIRECTIONAL SWIVEL LOCK OPT. III[®] FOR 360° MANEUVERABILITY</p>
--------------------	-----------------------	------------------------------	--

Other caster combinations available-call factory.

Top quality 3", 5", 6" or 8" non-marking wheels available

Parking brake*

Cover Color Choices

TAN	DARK BLUE	SLATE BLUE	RED*	TEAL*	CUSTOM*

* Many colors available

Cart Color Choices

Sparkling Silver (Standard Color)	Vanilla*	Granite*	Woodgrain*

Stenciling or Logo Available

Soft Cover for Basket Models
*ADDITIONAL CHARGE

Drape Cover for upright bulk carts

Ergonomic Spring Platform Bottoms Available

Spring Bottom

DESIGN YOUR OWN

CREATE-a-CART

Fax or email your design for pricing: Fax 830-401-0600 / sales@tqind.com

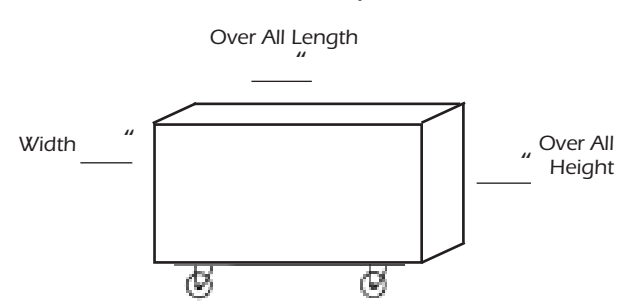
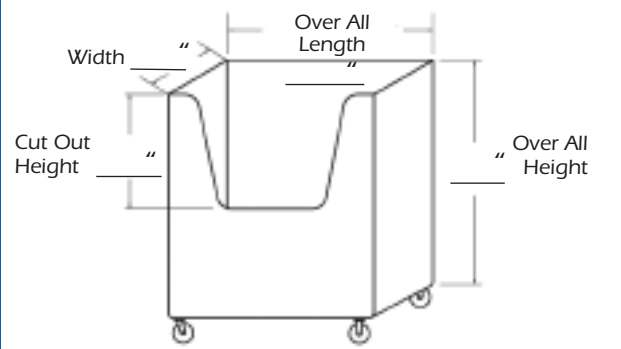

Your name and contact information: _____

CALL OUR CART EXPERTS! 800-826-1245



960 Crossroads Blvd. • Seguin, Texas 78155 • Local & Int'l Ph: 830-401-4400
 Fax: 830-401-0600 www.tqind.com • Email: sales@tqind.com • Toll Free **800-826-1245**





BIO-BOX & CUSTOM TRANSPORT CARTS



Since 1961

Collect Multiple Bio-Hazardous Boxes Easily & Deliver to Collection Point in these Easy to Handle Carts!

Saves Time • Saves Money • Meets Regulations • Employee Friendly

ALT-BB Made to "YOUR" specifications:

- Carry multiple boxes - at one time
- Engineered to be easy to unload.
- **YOU Specify the Height + Size** - depending on how many boxes you would like to carry (stacked or side x side)
- **YOU Specify the Number of Doors** you require for loading and unloading

This ALT-BB was made for our customer in the size 43" w x 62" l x 49" o.h. It carries 6 boxes of the size 19" w x 19" l x 32" o.h. They requested doors on all 4 sides of the cart.

You Design It - We Build It!

Heavy Duty Metal Perimeter Frame - Reinforced

Heavy Duty Corner Bumper + Full Wrap Around Bumper

Stainless Hinges



3- point locking latch with keyed or digital lock



Aluminum Exterior Panels and Doors

Large 8" x 2 ball bearing Quiet Wheels and casters

P-110-B Open Model with Access Doors

Durable Aluminum Construction

Perfect for Transports:

- Multiple Bio-Boxes
- Recycling Bins or Bags
- Corrugated flattened boxes or any other transport issues you have.

Standard P-110 Model Sizes (see below) or Built-To-YOUR-Requested Size with the Access doors and Accessories you need.

P-110-1	24" w X 48" l
P-110-2	24" w X 54" l
P-110-3	24" w X 60" l
P-110-4	24" w X 66" l
P-110-5	30" w X 48" l
P-110-6	30" w X 54" l
P-110-7	30" w X 60" l
P-110-8	30" w X 66" l
P-110-SP	Your Custom Size

Many Different Side and Handle Options Available

Towing Hitches Available

Heavy Duty Bumpers
Large 8" x 2 ball bearing wheels and casters



Our in house Cart Specialists will work with your criteria and create a CAD version of your design! It's Easy - Call Today!



FIRE RETARDANT



960 Crossroads Blvd. • Seguin, Texas 78155 • Local & Int'l Ph: 830-401-4400
Fax: 830-401-0600 www.tqind.com • Email: sales@tqind.com • Toll Free 800-826-1245



PROUDLY MADE IN THE U.S.A.



ALT - SERIES & CUSTOM CARTS

BUILT TO YOUR DESIGN & IDEAS



Since 1961

Collection Carts For Waste, Recycling, Soiled Linen, Decontamination, Bio-Boxes & More! Affordably

IF YOU CAN DRAW IT (or dream it) - WE CAN BUILD IT!

ALT - 100 Model

Aluminum Body and Stainless Steel Frame



Base standard size:
31" w x 61" l x (height any size you desire)

- **The ALT-100 can be made taller or shorter!**
- **Specify any door arrangement "you" need! We can do it!**

ALT-100 standard with:
Fiberglass seamless base, bumper and drain-holes with plugs

ALT - 201

Custom Design Model

What does your department need?



A few samples of ALT-201's we have built for customers

Cart A: size 30" w x 72" l x 56" o.h. with 2 front doors + cut out top and attached cover

Cart B: size 30" w x 60" l x 60" o.h. with 2 front doors

See reverse side for **Build- a- Cart** form and directions

TQ-400-S



We customized our standard TQ-400 model in *aluminum* to the customer's size requirement!

Size shown: 20" w x 45" l x 45" o.h. with front and top doors.

Aluminum fabrication allows us to build the TQ-400-S in the size "you need" and with any door configuration.

Call us with your ideas!



ALT-S

Create a Small Model

This beautiful cart looks terrific rolling down the hallways

Scratch Resistant Vanilla Aluminum Exterior Finish with Bronze Frame, Upper loading door and side or front unloading. **What's your idea?**

Shown here in custom size of: 20" w X 45" l X 50" o.h.

ALUMINUM BASKET CARTS Durable & Beautiful

Available in **standard commercial sizes of 10 bushel - to- 36 bushel or create your own unique size - larger or smaller!** Upgrades: Spring Platform Bottoms, Bumpers, Covers and push Handles



ALT - 250

Change the Size and Features of this Model - to meet your needs

This good looking rounded design with color coded panel doors was created by our customer!

ALT-250 can be made larger (as shown) **or in smaller sizes-**

Options: Interior dividers (create compartments for different types of soiled products). Towing hitches (as shown), Tambour doors - your ideas?



View the carts in action on:

Consult one of our in-house experts today - they "can" help you create the cart you need 100%.



960 Crossroads Blvd. • Seguin, Texas 78155 • Local & Int'l Ph: 830-401-4400

Fax: 830-401-0600 www.tqind.com • Email: sales@tqind.com • Toll Free **800-826-1245**





Metal Hampers for Soiled Linen and Medical Waste



Since 1961

Step On Lid • Variety of Bag Colors and Fabrics

Team Up These Hampers with your Larger Collection Carts

TQ-92 and TQ-50



**TQ-69-SS All Stainless Model
TQ-68 All Metal Model**

Variety of Bag Colors and Fabrics

TQ-82 and TQ-72



TQ-72
EZ to unload Zipper on bag

TQ-82
Leak proof bag

Model	Description	Weight
TQ-92	Economical All Metal Hamper with Step on ABS Plastic Lid. Made From 7/8" Steel Tubing Chrome Plated, 3" wheels w/parking brake and bottom shelf. Size: 17" w x 18" l x 34" OH	20
TQ-50	Economical All Metal Hamper with Step on ABS Plastic Lid. Made From 7/8" Steel Tubing Chrome Plated, 3" wheels w/parking brake and bottom shelf. Size: 18" w x 19" l x 38 1/2" OH	20
TQ-69	Triangular Hamper with Step on Metal Lid. All Metal Unit powder coated silver. Variety of bags: Cotton, Nylon, Leakproof bag and antimicrobial. Size: 21" w x 21" l x 32" OH	23
TQ-69 SS	Stainless Steel Triangular Hamper with Step on Metal Lid. Variety of bags: Cotton, Nylon, Leakproof bag and antimicrobial. Size: 21" w x 21" l x 32" OH	30
TQ-82	Deluxe- Leak Proof- All metal 7/8" tubing chrome finish with foot pedal step on ABS plastic lid, 4" non-marketing wheels, parking brake & bottom shelf. One Leak Proof Vinyl Bag – with shock cord – Bag Colors: White, Green, Pink, Blue. Size: 18 1/2" l x 17 3/4" w x 37 1/2" OH	32
TQ-72	Premium Step on Single Easy Access Zipper Bag hampers. All metal 7/8" tubing chrome finish with foot pedal step on ABS plastic lid, 4" non-marketing wheels and parking brake. One Leak proof Vinyl Bag – with zipper and shock cord – Bag Colors: White, Green, Pink, Blue. Size: 18 1/2" l x 17 3/4" w x 37 1/2" OH	34
TQ-94	Double Hamper All metal 7/8" tubing chrome finish with foot pedal step on ABS plastic lid, 3" wheels, parking brake. Lids available in several colors. Double Size: 17" w x 39" l x 35" OH	36

**TQ-94
Double
Hamper**



**Labeling
\$8.00
Each**



Most models Shipped knocked down. Call for details.

Call the Hamper Specialists at 800-826-1245



960 Crossroads Blvd. • Seguin, Texas 78155 • Local & Int'l Ph: 830-401-4400

Fax: 830-401-0600 www.tqind.com • Email: sales@tqind.com • Toll Free **800-826-1245**



**FIRE
RETARDANT**





"Finally" A Housekeeping Cart Available in a Variety of Colors to Match "Your" Decor

Standard Features

All Aluminum Construction! 1/2 the weight of stainless and 1/2 the price.

Made in USA.

Micro-fiber or Bucket/Wringer Style!

- Adjustable Interior Shelf
- Cabinet and Cart may be Modified to Another Size to Meet "Your" Needs
- Locking Door Model or Open Front
- 5" Wheels and Parking Brake
- Mop and Broom Holders
- Variety of Bag Colors
- EZ Opening Zippers on Bags - **No** Lifting
- Bumpers



LC-100



Model	Overall Dimensions
LC-100- Janitorial	23" W x 36" L x 40" OH with 12" Bag
LC-S	Custom Size
Express Plus Cart	23" x 24"L x 40" OH (bag over platform)
Recessed Top (Both Models)	15"L x 21"W x 5"D
Enclosed Storage Area with Adjustable Shelf	16"W x 22"D x 30" H



Variety of Exterior Colors



Custom Color
Call with your ideas

Perimeter Bumper Colors



Bag Colors



Custom Color
Call with your ideas



LC-100
In Vanilla Color



Recessed Top



Express Plus Multi-Purpose Cart shown in Custom Mahogany Color



960 Crossroads Blvd. • Seguin, Texas 78155 • Local & Int'l Ph: 830-401-4400
Fax: 830-401-0600 www.tqind.com • Email: sales@tqind.com • Toll Free 800-826-1245



INTRODUCING The First Mobile Collection Carts For Recycling



S-3 See other models on reverse page

- Plastic ▪ Glass ▪ Aluminum ▪ Cans
- Green Waste ▪ Paper ▪ Etc.

- S-Series carts for collecting recyclable items throughout your facility!
- Assists housekeeping department, medical staff, patients and guests to recycle
- Sort and prepare for recycling into a larger container—
- Roll the S- Series to a larger cart or designated area to dispose of recycling
- Sort the items you would like to recycle in color coded bags with labels: Paper, Waste, Office Paper, Plastic, Glass, Cans, Organics, Your ideas?
- Sort bags are leak/ water proof made from flame proof durable vinyl material
- Commercial waste liners can be secured into bags and EZ to unload with full length zippers located on front of bags
- **Rolls with ease** equipped with large non-marking wheels and durable casters and corner bumper guards
- **Parking Brake** to keep cart in place
- Can ship dis-assembled to save shipping costs

SUSTAINABLE

TQ's S-Series are crafted from recycled durable aluminum alloy! PLUS the cart is recyclable at end of its life span!

Hospitals
Long Term Care • Clinics
Wellness Centers • Offices

Helping you comply with the Resource Conservation and Recovery Act

See the back for specifications, models, and choices ... or customize it!

Tecni-Quip
Carts



960 Crossroads Blvd. • Seguin, Texas 78155 • Local & Int'l Ph: 830-401-4400
Fax: 830-401-0600 www.tqind.com • Email: sales@tqind.com • Toll Free 800-826-1245

The Series makes Handling & Transporting Recycling as easy as 1-2-3!

1. choose a style



S-1



S-2



S-3



S-4

Shown with lower storage drawer on glide to place extra liners or supplies. See options below.

2. choose your bag colors to color code different types of waste



S-C



★
S-Enclosed

specifications

Model	Dimensions with Bumper
S-1	20" W x 30" L x 45" H
S-2	20" W x 30" L x 45" H
S-3	20" W x 45" L x 45" H
S-4	20" W x 56" L x 45" H
S-C	Custom
S-E	Enclose any model call for pricing



Bags opening easily!

3. choose logos for bags



4. select a frame color



5. select a base color



standard features

- Anodized aluminum construction.
- Bags contain zippers on front that allow soiled material to be removed easily from cart without lifting. (2 on S-1) Disposable liners fit inside vinyl bags.
- Bags are waterproof and lift out for cleaning with a variety of colors to keep sorting simple.
- Carts roll on large wheels and casters that are attached to a solid aluminum base.
- Full perimeter and rolling bumpers—protect walls and furnishings—can be adjusted to meet baseboards.
- Improves operational recycling.

options (call for pricing)

- Custom cart size, custom bag design or have your property's logo positioned on bags
- Hinged lids to cover top of cart with cut-outs for paper, aluminum cans, bottles & other recyclables
- Add to any model a lower storage drawer on glides, great for storing additional liners or supplies
- ★ Elegantly enclose any S- Series cart model on 3 sides of the cart with one of our décor exterior base colors. In doing this the back side of cart remains open with zippers facing out for unloading (faces wall during use)

customize it!

Have something else in mind? We can make it for you! Draw it and send to us...

Fax: 830-401-0600 or Email: tqcart@tqind.com

Tecni-Quip Carts

960 Crossroads Blvd. • Seguin, Texas 78155 • Local & Int'l Ph: 830-401-4400
Fax: 830-401-0600 www.tqind.com • Email: sales@tqind.com • Toll Free 800-826-1245

www.tqind.com • 800-826-1245 • Email: tqcart@tqind.com



OTHER GREAT TECNI QUIP PRODUCTS

Call Us for Information 800-826-1245



Enclosed Linen Carts - Various Sizes, Color Combinations & Models



Wire Carts & Shelving, Push Carts & Cart Covers for All Brands and Sizes of Carts



Round Trippers: Fiberglass, Stainless and Hybrid Wire



Custom Sizes and Carts!
Free Consultation and Design Work



960 Crossroads Blvd. • Seguin, Texas 78155 • Local & Int'l Ph: 830-401-4400
Fax: 830-401-0600 www.tqind.com • Email: sales@tqind.com • Toll Free 800-826-1245

